

# Theory Days 2026

26th April

## Lights Out Problem to Benchmark Real Quantum Hardware

Maksim Dimitrijevič, Maria Palchiha, Abuzer Yakaryilmaz

University of Latvia  
Center for Quantum  
Computing Science



arXiv:2602.16014

# School research project

Started as a school research project. Initially, 11<sup>th</sup> grade students were looking for a consultant in quantum physics. But got a consultant in quantum computing.

**Zinātniski  
pētnieciskais darbs  
ZPD**



# Initial idea

Right at the start of the collaboration, students let me know that would like to do some harder task. I proposed to look up some interesting task to solve with a Grover's Search, and run the algorithm on a real quantum computer.

Content Addressable L1 Cache



Unstructured Search in  $O(1)$  to find corresponding RAM-Address with 100% accuracy

Quantum Computers



Unstructured Search in  $O(\sqrt{n})$  with "high probability"

# Direction of the research has shaped

Lights Out problem with specific task conditions. Experiments for small instances on available IBM quantum computers did not provide reliable outcomes. The resulting problem was not NP-hard.



# Challenge accepted

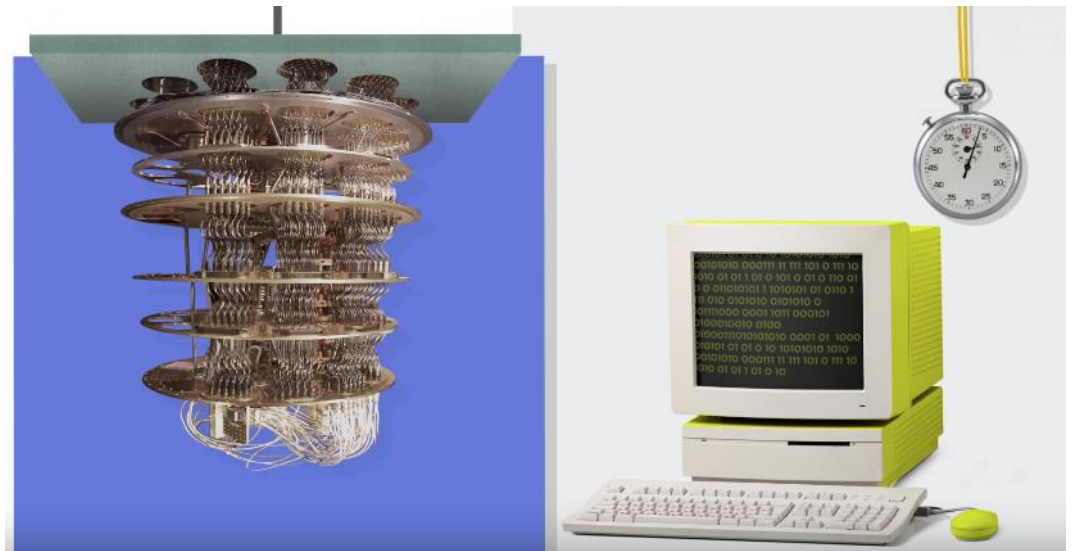

We have to design the instances of the problem that provide interesting outcomes on cloud quantum hardware with free access.

Idea for the paper emerged – let's benchmark quantum hardware on the chosen problem.

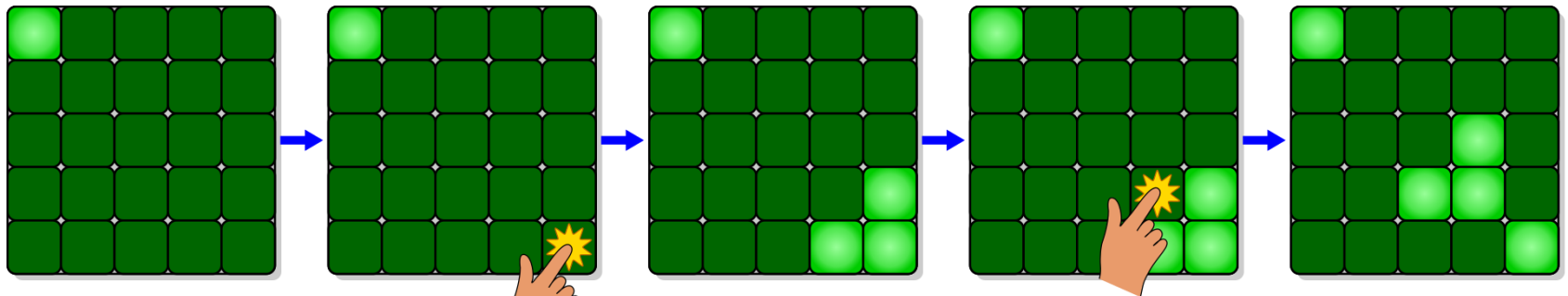

# Lights Out



-  On
-  Off
-  Select



# 2x2 grid of lamps

00	01
10	11

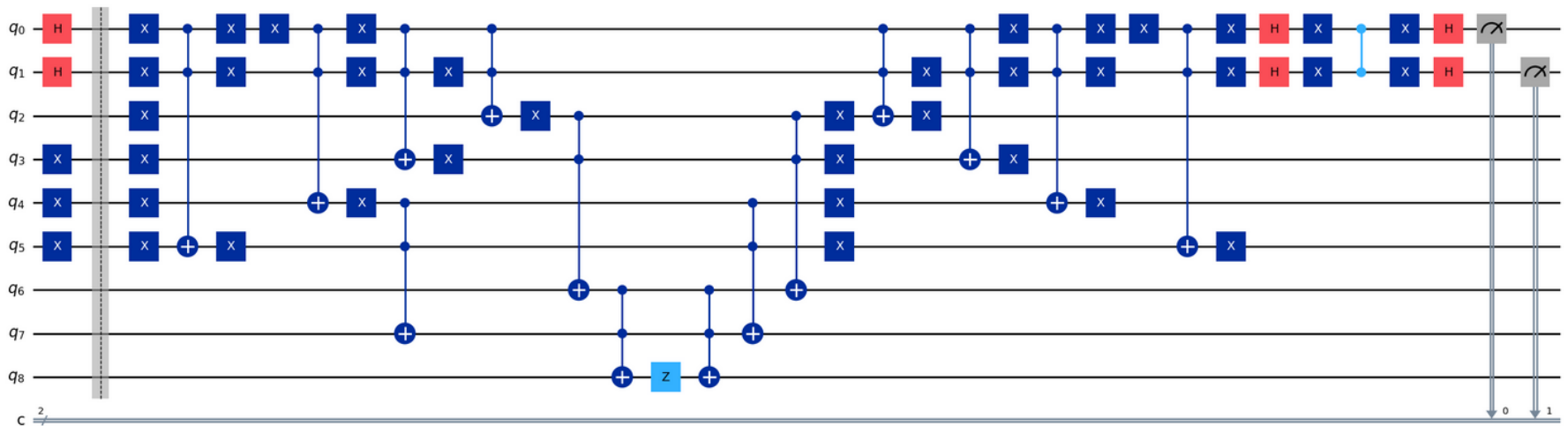

# 6 lamps on Möbius ladder

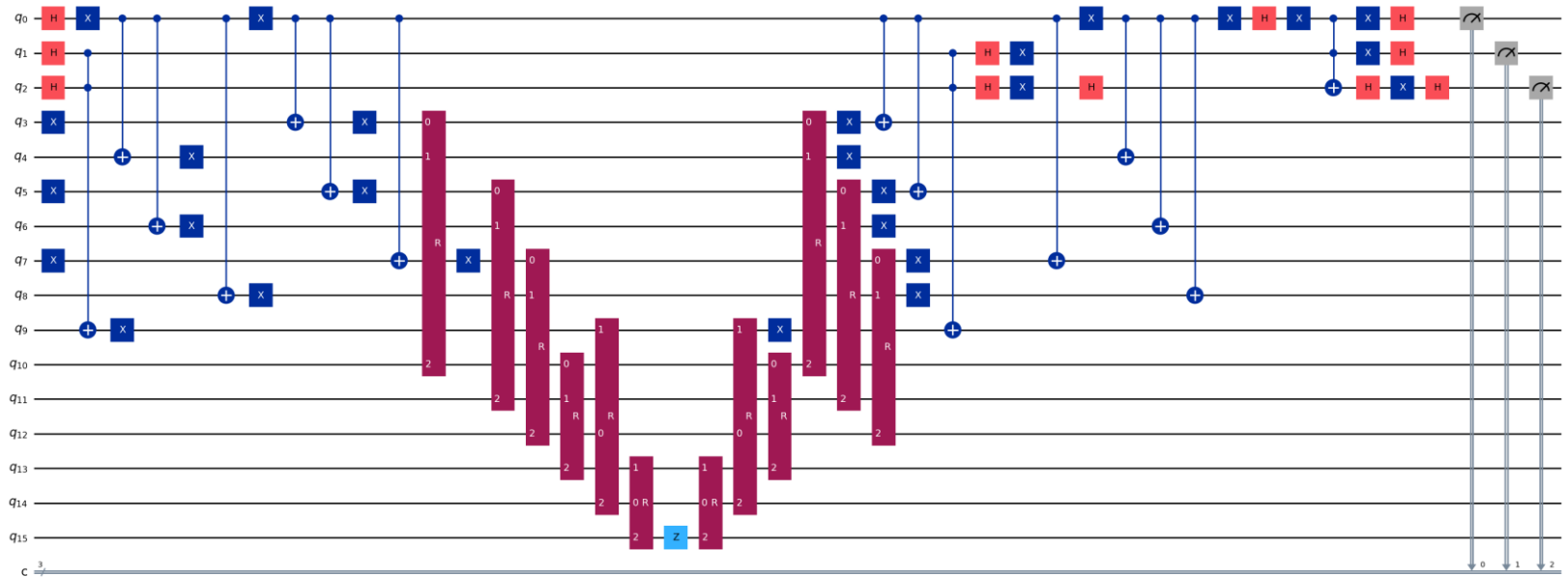
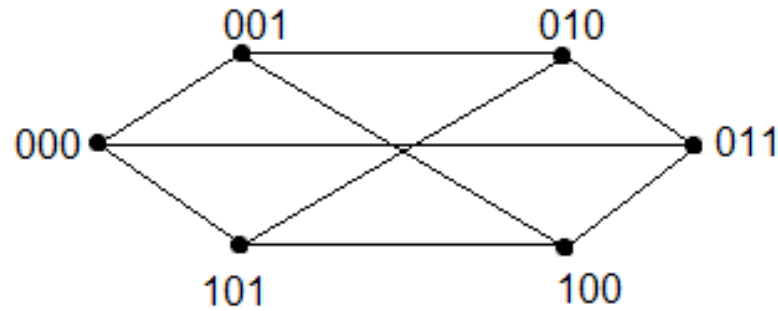

# IBM devices

- ibm\_marrakesh (Heron r2, 2024)
- ibm\_fez (Heron r2, 2024)
- ibm\_torino (Heron r1, 2023)

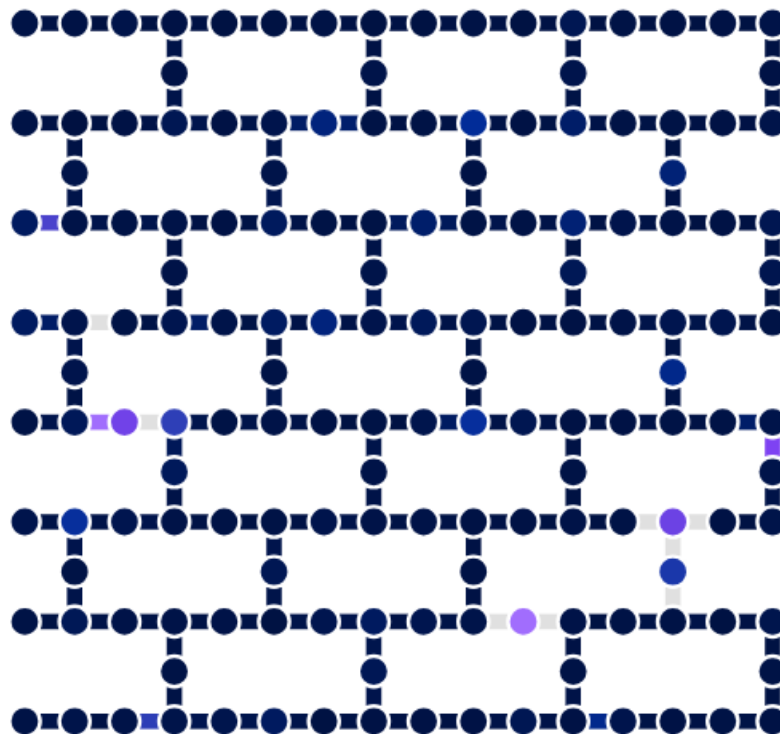

# IBM – transpilation statistics

2x2 lamps, on 9 qubits:

Mode	marrakesh			fez			torino		
	2q op	depth	size	2q op	depth	size	2q op	depth	size
composer	170	293	633	167	295	631	173	341	650
opt=3	165	397	714	173	437	754	170	430	720
opt=2	175	405	756	177	408	749	175	399	747
opt=1	217	467	932	229	554	962	199	455	882
opt=0	328	715	1560	376	774	1704	310	712	1506

6 lamps, on 16 qubits:

method	marrakesh			fez			torino		
	2q op	depth	size	2q op	depth	size	2q op	depth	size
opt=3	191	215	802	191	213	796	203	234	798
res=2	191	214	799	191	212	793	203	228	790
composer	243	227	748	219	206	685	234	257	739

# IQM devices

- IQM Emerald (54 qubits)
- IQM Garnet (20 qubits)
- IQM Sirius (16 qubits)

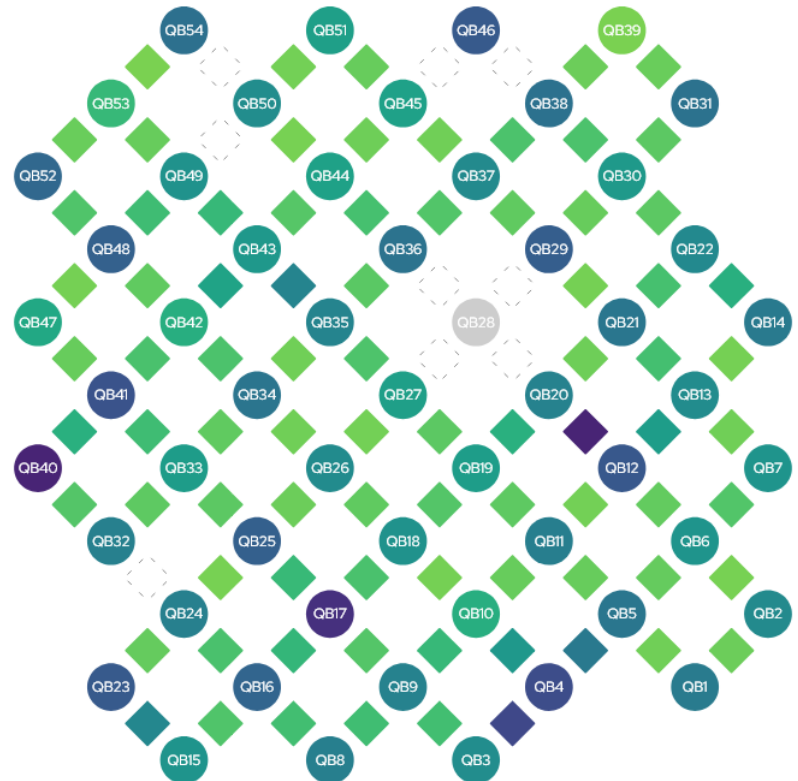
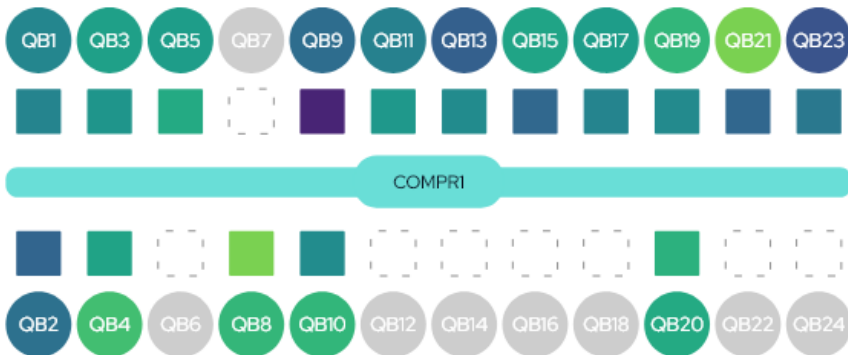

# IQM – transpilation statistics

2x2 lamps:

	Emerald				Garnet				Sirius			
Mode	qub	2q op	depth	size	qub	2q op	depth	size	qub	2q op	depth	size
opt=3	9	151	246	403	9	151	232	402	10	202	221	322
opt=2	9	152	230	392	9	145	227	397	10	202	221	322
opt=1	11	166	246	418	10	178	257	454	10	197	215	315
opt=0	12	244	673	1303	9	211	694	1204	10	227	582	968

6 lamps:

	Emerald				Garnet				Sirius			
Mode	qub	2q op	depth	size	qub	2q op	depth	size	qub	2q op	depth	size
opt=3	17	106	112	294	16	104	102	285	17	169	179	271
opt=2	16	109	103	304	17	123	106	333	17	169	179	271

# 2x2 lamps – experimental results

Mode	ibm_marrakesh	ibm_fez	ibm_torino
Composer	<b>11: 2304 (0.576)</b> 00: 515 01: 665 10: 516	<b>11: 1645 (0.411)</b> 00: 759 01: 828 10: 768	<b>11: 954 (0.239)</b> 00: 1014 01: 950 10: 1082
opt=3	<b>11: 2018 (0.505)</b> 00: 563 01: 716 10: 703	<b>11: 1417 (0.354)</b> 00: 853 01: 933 10: 797	<b>11: 1796 (0.449)</b> 00: 599 01: 896 10: 709
opt=2	<b>11: 1896 (0.474)</b> 00: 621 01: 731 10: 752	<b>11: 1528 (0.382)</b> 00: 842 01: 814 10: 816	<b>11: 1633 (0.408)</b> 00: 709 01: 858 10: 800
opt=1	<b>11: 1780 (0.445)</b> 00: 644 01: 868 10: 708	<b>11: 1460 (0.365)</b> 00: 718 01: 865 10: 957	<b>11: 1553 (0.388)</b> 00: 754 01: 934 10: 759
opt=0	<b>11: 1370 (0.343)</b> 00: 749 01: 1090 10: 791	<b>11: 1035 (0.259)</b> 00: 937 01: 1097 10: 931	<b>11: 1081 (0.270)</b> 00: 942 01: 1091 10: 886

Mode	Emerald	Garnet	Sirius
opt=3	266	258	277
opt=2	218	230	269
opt=1	246	289	277
opt=0	265	284	242

# 6 lamps – experimental results

Device	Sampler (opt=3)	Estimator ( $r=0$ )	Estimator ( $r=1$ )	Estimator ( $r=2$ )	Comp.
marrakesh	0.4355	$0.4637 \pm 0.0076$	$0.4809 \pm 0.0085$	$0.5358 \pm 0.0957$	0.3753
fez	0.390	$0.3398 \pm 0.0076$	$0.3423 \pm 0.0074$	$0.4280 \pm 0.1223$	0.3345
torino	0.374	$0.4293 \pm 0.0075$	$0.4307 \pm 0.0074$	$0.4594 \pm 0.0279$	0.373

Mode	Emerald			Garnet			Sirius		
opt=3	<b>total: 441 (0.441)</b>			<b>total: 397 (0.397)</b>			<b>total: 465 (0.465)</b>		
	001: 191	011: 148	101: 102	001: 111	011: 198	101: 88	001: 235	011: 148	101: 82
opt=2	<b>total: 346 (0.346)</b>			<b>total: 305 (0.305)</b>			<b>total: 475 (0.475)</b>		
	001: 113	011: 130	101: 103	001: 110	011: 96	101: 99	001: 238	011: 153	101: 84

# IQM – smaller circuit

SAT instance for  $q_0 \wedge \neg q_1$

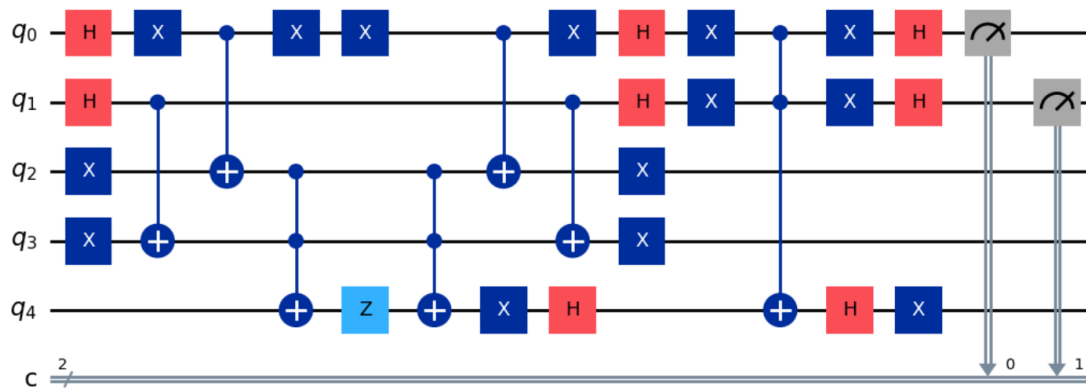

Device	opt=3	opt=0
Emerald	<b>01: 409 (0.409)</b> 00: 148 10: 135 11: 308	<b>01: 241 (0.241)</b> 00: 210 10: 264 11: 285
Garnet	<b>01: 630 (0.630)</b> 00: 105 10: 68 11: 197	<b>01: 509 (0.509)</b> 00: 128 10: 190 11: 173
Sirius	<b>01: 258 (0.258)</b> 00: 250 10: 237 11: 255	<b>01: 260 (0.260)</b> 00: 263 10: 255 11: 222

# IQM – 2-qubit circuit

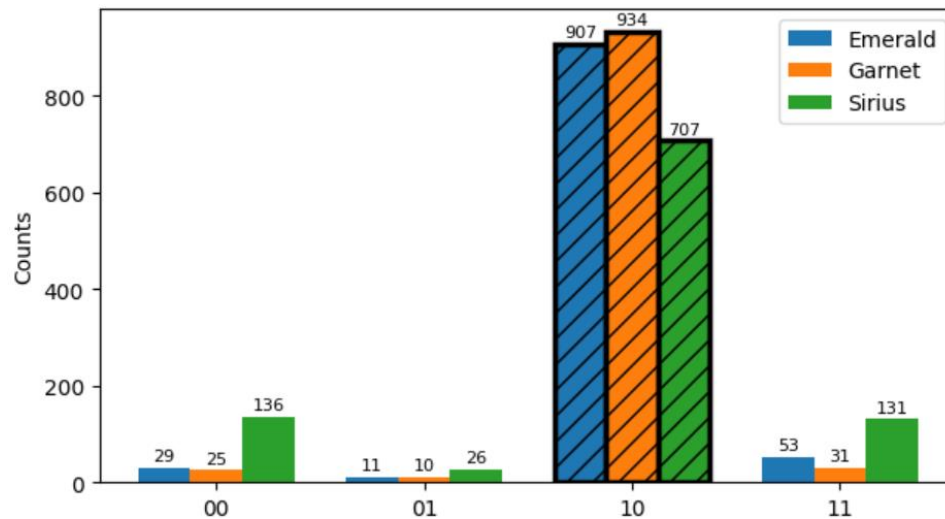
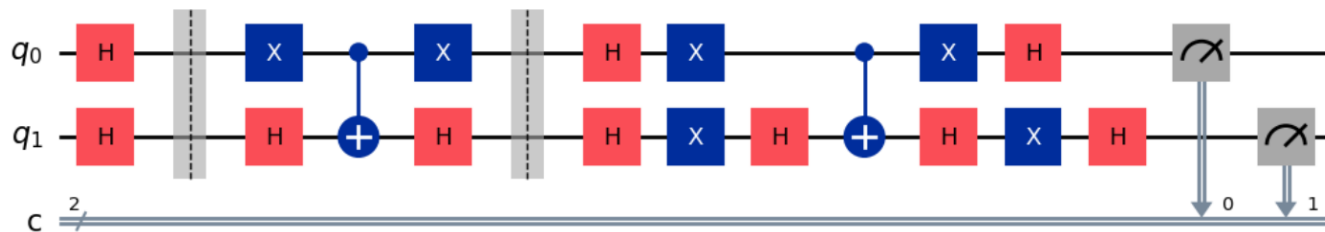

# Conclusions

The current hardware available for free is capable of running circuits that exceed a depth of 700, having more than 300 two-qubit operations.

The circuit for Möbius ladder with 6 lamps can serve as an interesting benchmark for upcoming new hardware.

IBM had some progress in the year 2023-2024.

Manufacturing quality has a significant impact on QPUs, and newer devices may underperform compared to older ones. Calibration has a significant effect on performance, and theoretically “weakest” device can surpass the “strongest” one.

# Calibration

ibm\_miami



Search by qubit number

Qubit	T1 (us)	T2 (us)	Readout assignment error	Prob meas0 prep1	Prob meas1 prep0	Readout length (ns)
0	223.1	222.38	4E-1	0.09692	0.70313	2,400
1	403.54	489.46	3.424E-1	0.20435	0.48047	2,400
2	543.06	317.19	4.32E-1	0.13306	0.73096	2,400
3	504.39	538.24	3.17E-1	0.01416	0.42334	2,400
4	558.2	508.01	3.644E-1	0.15332	0.57544	2,400
5	246.42	275.47	3.262E-1	0.28613	0.36621	2,400
6	14.73	26.1	4.076E-1	0.65576	0.15942	2,400
7	85.26	138.65	3.77E-1	0.38574	0.36816	2,400

**Thank you for your  
attention!**

